

### 5.31 atleast\_nvector

|                      | DESCRIPTION   | LINKS | GRAPH |
|----------------------|---|-------|-------|
| <b>Origin</b>        | Derived from <code>nvector</code>   |       |       |
| <b>Constraint</b>    | <code>atleast_nvector(NVEC, VECTORS)</code>   |       |       |
| <b>Type</b>          | <code>VECTOR : collection(var-dvar)</code>  |       |       |
| <b>Arguments</b>     | <code>NVEC : dvar</code><br><code>VECTORS : collection(vec - VECTOR)</code>   |       |       |
| <b>Restrictions</b>  | <code>NVEC ≥ 0</code><br><code>NVEC ≤  VECTORS </code><br><code>required(VECTORS, vec)</code><br><code>same_size(VECTORS, vec)</code>   |       |       |
| <b>Purpose</b>       | The number of distinct tuples of values taken by the vectors of the collection <code>VECTORS</code> is greater than or equal to <code>NVEC</code> . Two tuples of values $\langle A_1, A_2, \dots, A_m \rangle$ and $\langle B_1, B_2, \dots, B_m \rangle$ are <i>distinct</i> if and only if there exist an integer $i \in [1, m]$ such that $A_i \neq B_i$ .  |       |       |
| <b>Example</b>       | $\left( 2, \left\langle \begin{array}{l} \text{vec} - \langle 5, 6 \rangle, \\ \text{vec} - \langle 5, 6 \rangle, \\ \text{vec} - \langle 9, 3 \rangle, \\ \text{vec} - \langle 5, 6 \rangle, \\ \text{vec} - \langle 9, 4 \rangle \end{array} \right\rangle \right)$   |       |       |
|                      | The <code>atleast_nvector</code> constraint holds since the collection <code>VECTORS</code> involves at least 2 distinct tuples of values (i.e., in fact the 3 distinct tuples $\langle 5, 6 \rangle$ , $\langle 9, 3 \rangle$ and $\langle 9, 4 \rangle$ ).  |       |       |
| <b>Typical</b>       | <code>NVEC &gt; 1</code><br><code>NVEC &lt;  VECTORS </code><br><code> VECTOR  &gt; 1</code><br><code> VECTORS  &gt; 1</code>   |       |       |
| <b>Symmetries</b>    | <ul style="list-style-type: none"> <li>• <code>NVEC</code> can be <b>decreased</b> to any value <math>\geq 0</math>.</li> <li>• Items of <code>VECTORS</code> are <b>permutable</b>.</li> <li>• Items of <code>VECTORS.vec</code> are <b>permutable</b> (<i>same permutation used</i>).</li> <li>• All occurrences of two distinct tuples of values of <code>VECTORS.vec</code> can be <b>swapped</b>; all occurrences of a tuple of values of <code>VECTORS.vec</code> can be <b>renamed</b> to any unused tuple of values.</li> </ul> |       |       |
| <b>Reformulation</b> | By introducing an extra variable $NV \in [0,  \text{VECTORS} ]$ , the <code>atleast_nvector(NV, VECTORS)</code> constraint can be expressed in term of an <code>nvector(NV, VECTORS)</code> constraint and of an inequality constraint $NV \geq \text{NVEC}$ .  |       |       |

**See also**

**comparison swapped:** `atmost_nvector`.

**generalisation:** `nvector` ( $\geq$  NVEC *replaced by* = NVEC).

**implied by:** `ordered_atleast_nvector`.

**used in graph description:** `lex_equal`.

**Keywords**

**characteristic of a constraint:** `vector`.

**constraint type:** counting constraint, value partitioning constraint.

**final graph structure:** strongly connected component, equivalence.

**modelling:** number of distinct equivalence classes.

**problems:** domination.

|                            |  |
|----------------------------|--|
| <b>Arc input(s)</b>        | VECTORS  |
| <b>Arc generator</b>       | <i>CLIQUE</i> $\mapsto$ <code>collection</code> (vectors1, vectors2) |
| <b>Arc arity</b>           | 2  |
| <b>Arc constraint(s)</b>   | <code>lex_equal</code> (vectors1.vec, vectors2.vec)                  |
| <b>Graph property(ies)</b> | $\text{NSCC} \geq \text{NVEC}$                                       |
| <b>Graph class</b>         | <i>EQUIVALENCE</i>   |

**Graph model**

Parts (A) and (B) of Figure 5.59 respectively show the initial and final graph associated with the **Example** slot. Since we use the **NSCC** graph property we show the different strongly connected components of the final graph. Each strongly connected component corresponds to a tuple of values that is assigned to some vectors of the **VECTORS** collection. The 3 following tuple of values  $\langle 5, 6 \rangle$ ,  $\langle 9, 3 \rangle$  and  $\langle 9, 4 \rangle$  are used by the vectors of the **VECTORS** collection.

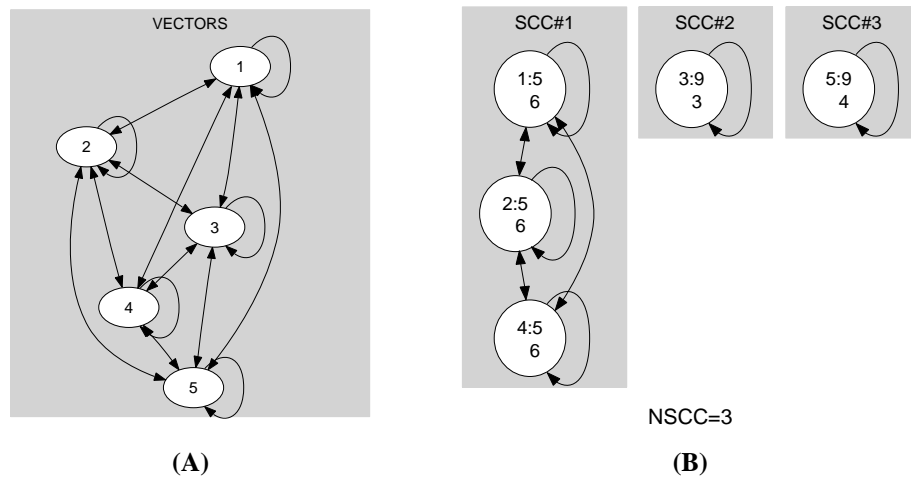

Figure 5.59: Initial and final graph of the `atleast_nvector` constraint

